

PoC Filter Solution – SMD-POC-003

- PoC solution for 1 MHz – 4.2 GHz applications
- Designed specifically for 8.4 Gbps chipsets with backwards capabilities.
- 125°C ambient applications: 800 mA
- 105°C ambient applications: 900 mA
- 85°C ambient applications: 900 mA

Inductors	DCR max. (Ohms)	Max. Area (mm ²)	Isat (A) 30%				Irms (A)			
			25°C	85°C	105°C	125°C	25°C	85°C	105°C	125°C
0402DF-560 (0.056 uH)	0.061	0.73	1.2	1.1	1.0	1.0				
PFL2010-471 (0.47 uH)	0.069	3.19	1.9	1.9	1.5	1.1	1.8	1.4	1.2	0.97
1812PS-103 (10 uH)	0.170	29.23	1.7	1.5	1.2	0.9	1.0	0.92	0.88	0.8
MSS1048T-104 (100 uH)	0.224	108.15	1.48	1.39	1.3	1.2	1.36	1.2	1.1	1.0
Totals:	0.524	141.3								

Schematic

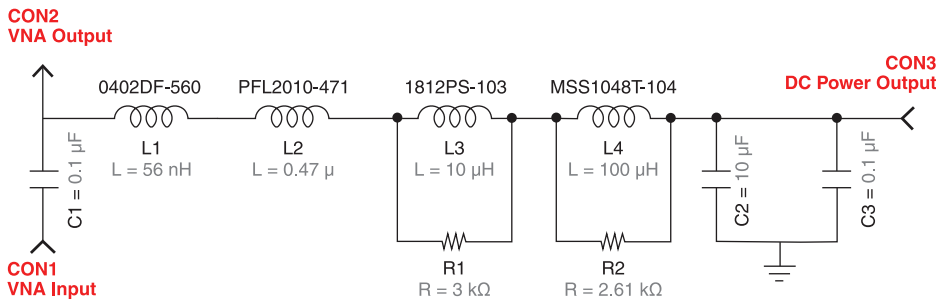

Total Channel Test Setup

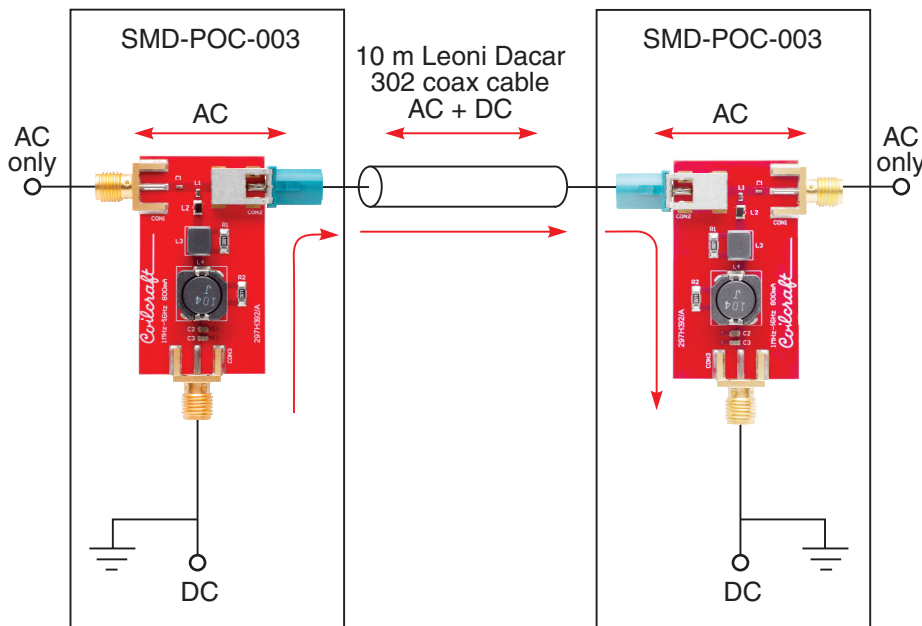

* Solutions measured in a total channel configuration. 2 PCB's with PoC filters on each with a 10 m Leoni Dacar 302 cable interconnect.

PoC Filter Solution – SMD-POC-003

Return Loss (S11, Single board no current)

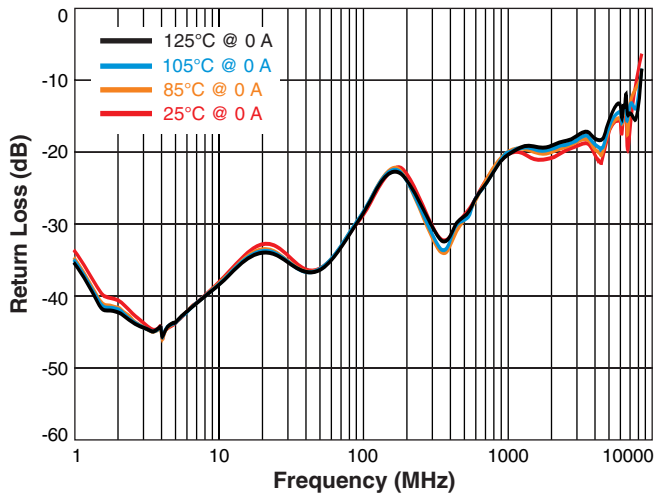

Insertion Loss (S21, Single board no current)

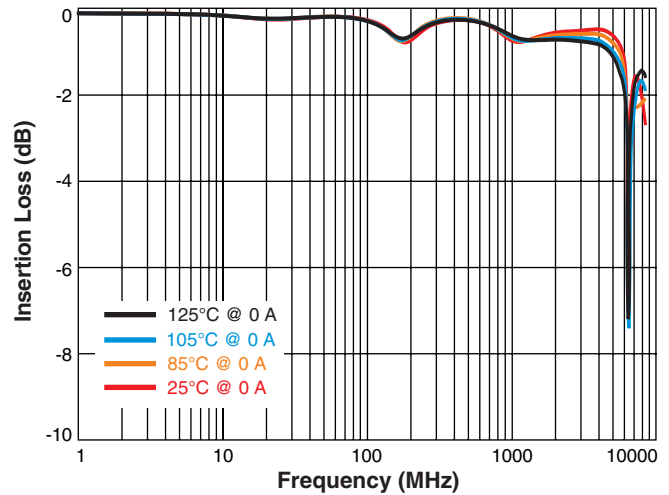

Return Loss (S11, Total Channel Measurements*)

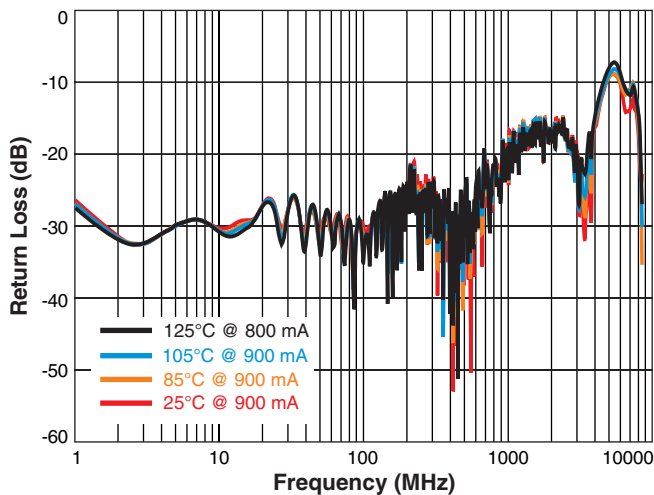

Insertion Loss (S21, Total Channel Measurements*)

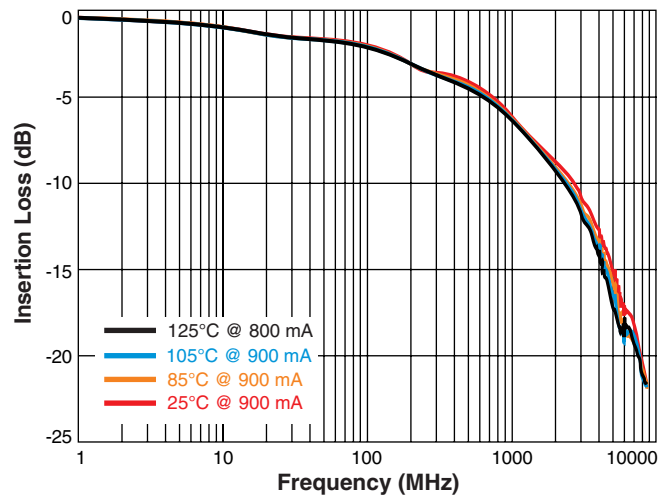

* Solutions measured in a total channel configuration. 2 PCB's with PoC filters on each with a 10 m Leoni Dacar 302 cable interconnect.