

# PoC Filter Solution – SMD-POC-030

## Overview

The SMD-POC-030 is for PoC applications spanning a 1 MHz to 3 GHz frequency range, injecting a current of 0.28 Amps at 105°C. The impedance measurement was generated in simulation using measured Z-Parameter files for each component. S-Parameters were generated by taking two SMD-POC-030 boards connected by Leoni Dacar-302 coaxial cable. Using a DC Power supply, the DC<sub>in</sub> was connected to CON3 of the first board, while the DC<sub>out</sub> was connected to the CON3 of the second board to close the circuit. All measurements were at room temperature and are considered typical responses for the solution.

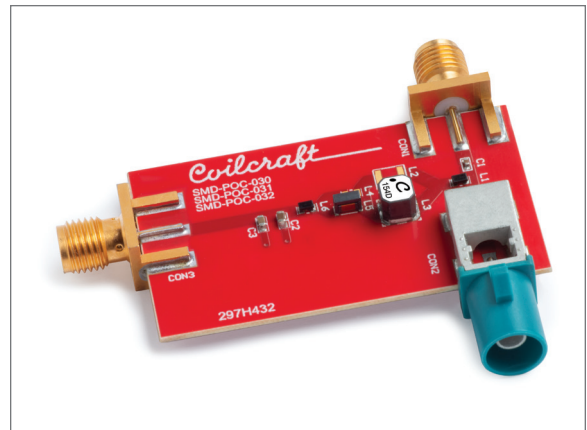

## Coilcraft 280 mA at 105°C Solution

Inductors	DCR max. (Ohms)	Max. Area (mm <sup>2</sup> )	Isat (A) 30%		Irms (A)		Notes
			25°C	125°C	25°C	125°C	
PFL1609-561 (0.56 µH)	0.130	1.926	1.10	0.61	1.40 (40°C rise)	0.80 (15°C rise)	
LPS4040-154 (150 µH)	0.680	15.81	0.32	0.22	0.65 (40°C rise)	0.50 (40°C rise)	
1205POC-103 (10 µH)	1.000	4.48	0.67	0.41	0.56 (40°C rise)	0.30 (15°C rise)	
PFL1609-222 (2.2 µH)	0.470	1.926	0.47	0.29	0.63 (40°C rise)	0.33 (15°C rise)	
<b>Totals:</b>	<b>2.280</b>	<b>24.142</b>					

## Schematic

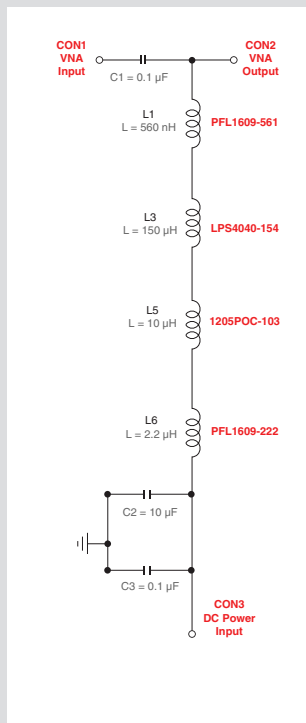

## Impedance vs. Frequency

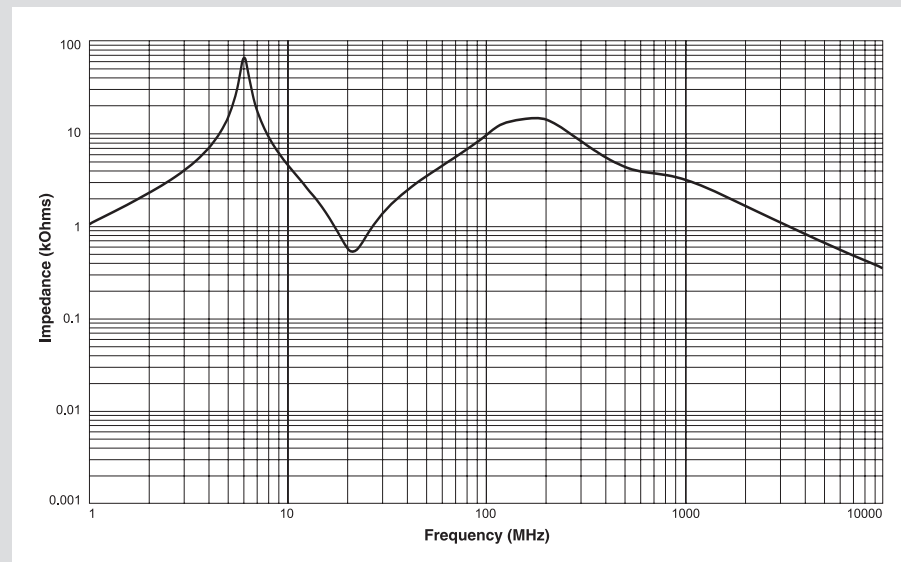

# PoC Filter Solution – SMD-POC-030

**Return Loss (2 m cable)**

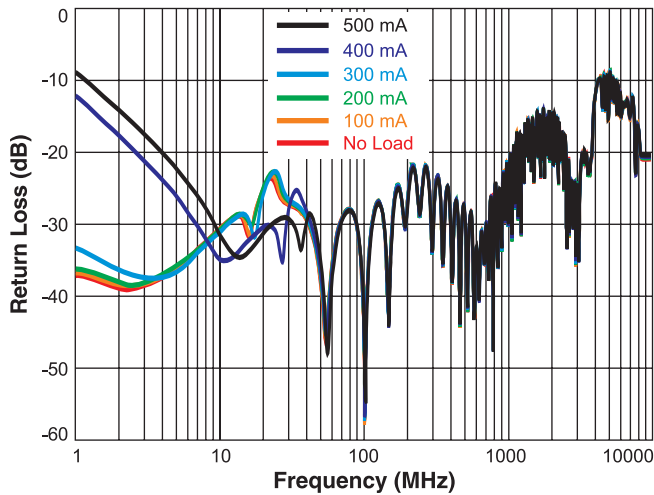

**Return Loss (10 m cable)**

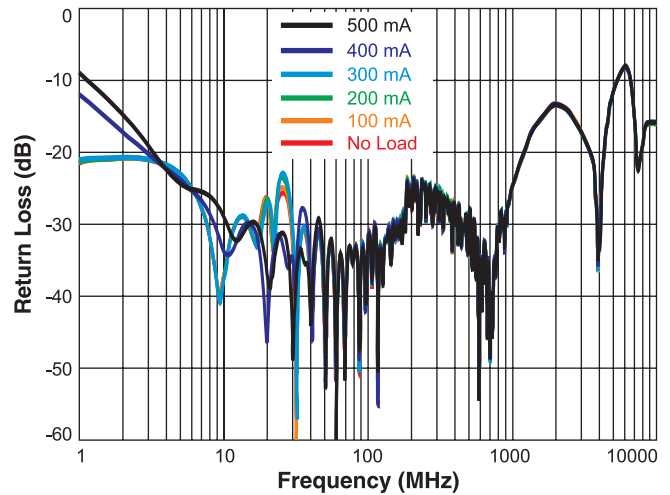

**Insertion Loss (2 m cable)**

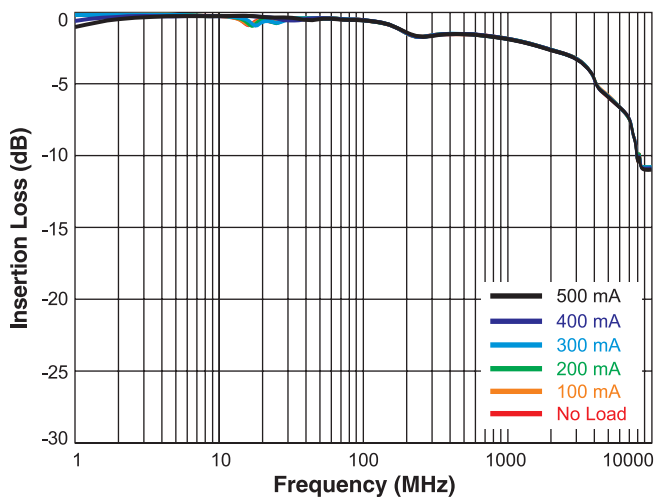

**Insertion Loss (10 m cable)**

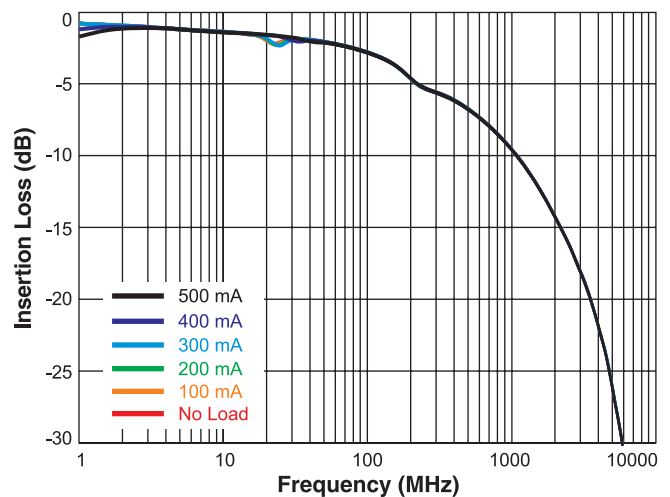

# PoC Filter Solution – SMD-POC-030

## S-Parameters (280 mA, 2 m cable at temperature)

