

PoC Filter Solution – SMD-POC-005

- PoC solution for 8 MHz – 3 GHz applications
- Designed specifically 3 Gbps and 6 Gbps chipsets
- Less than 10 mm² of board space with 3.0 mm maximum height
- 125°C ambient applications: 300 mA
- 105°C ambient applications: 350 mA
- 85°C ambient applications: 400 mA

Inductors	DCR max. (Ohms)	Max. Area (mm ²)	Isat (A) 30%				Irms (A)			
			25°C	85°C	105°C	125°C	25°C	85°C	105°C	125°C
PFL1005-561 (560 nH)	0.54	0.72	0.49	0.42	0.36	0.33	0.53	0.52	0.40	0.30
1210POC-223 (22 uH)	0.88	8.81	0.72	0.58	0.52	0.45	0.70	0.63	0.48	0.40
Totals:	1.42	9.53								

Schematic

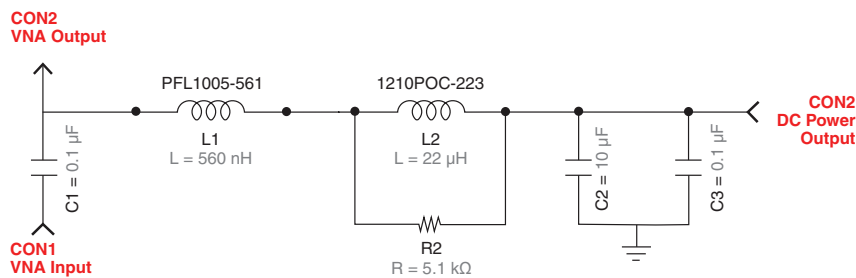

Total Channel Test Setup

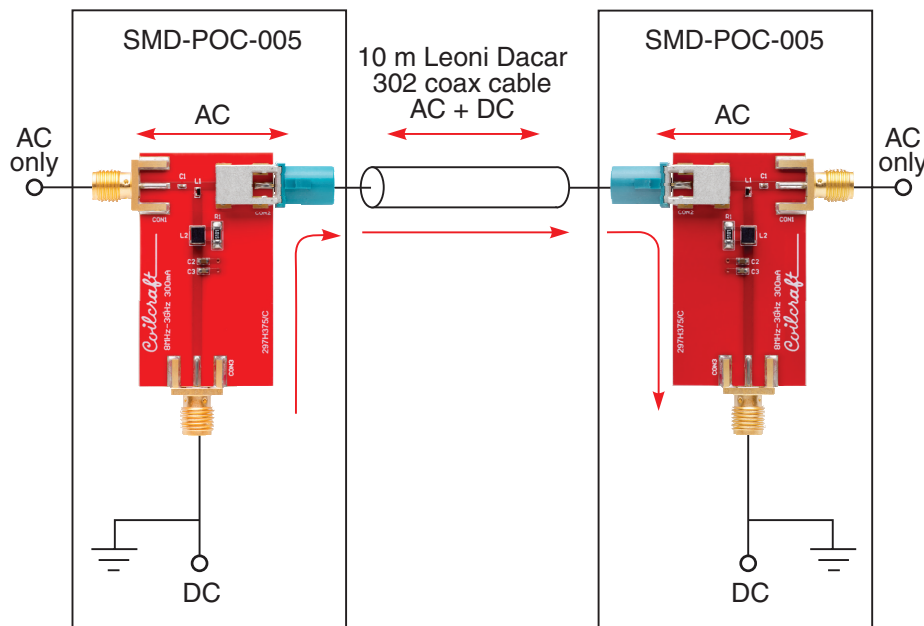

* Solutions measured in a total channel configuration. 2 PCB's with PoC filters on each with a 10 m Leoni Dacar 302 cable interconnect.

PoC Filter Solution – SMD-POC-005

Return Loss (S11, Single board no current)

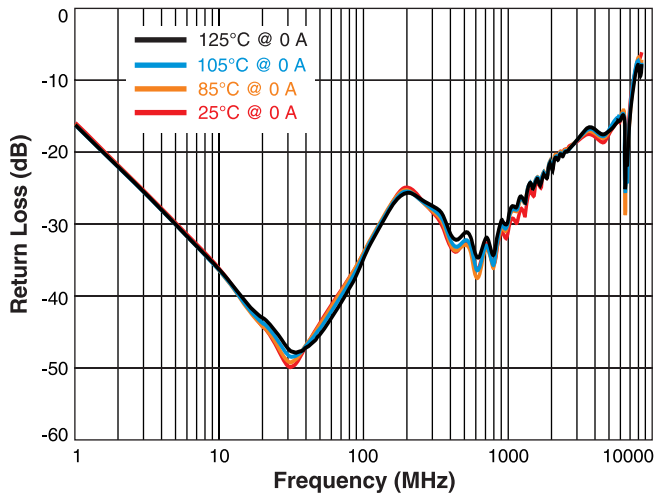

Insertion Loss (S21, Single board no current)

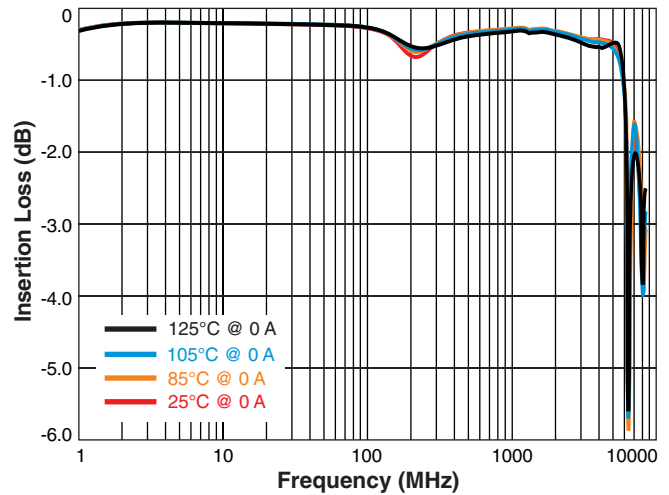

Return Loss (S11, Total Channel Measurements*)

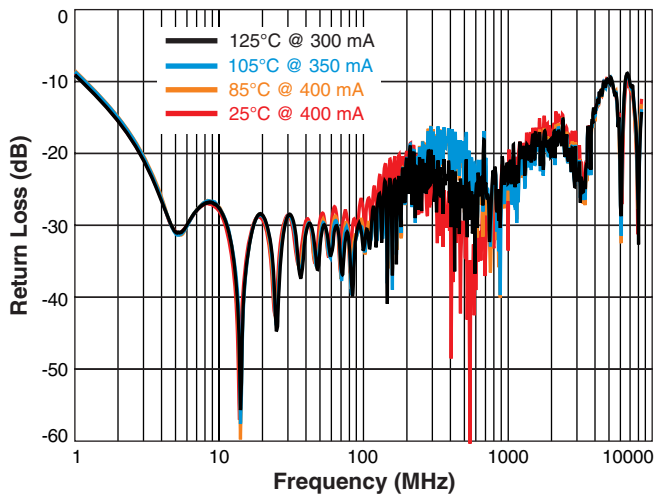

Insertion Loss (S21, Total Channel Measurements*)

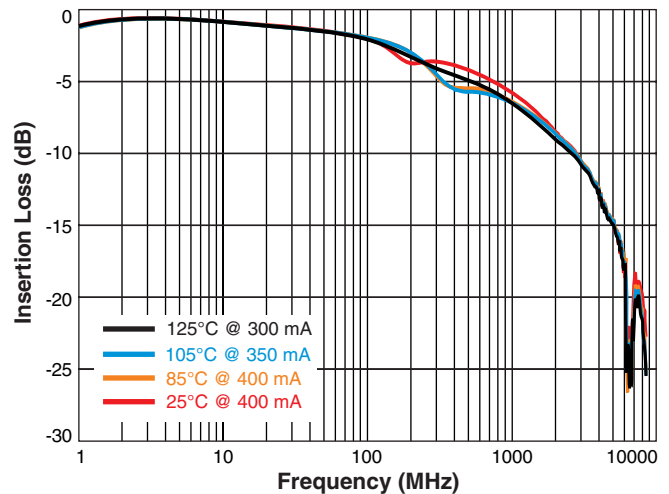

* Solutions measured in a total channel configuration. 2 PCB's with PoC filters on each with a 10 m Leoni Dacar 302 cable interconnect.