

Shielded Power Inductors - LPS3015

Improved version now available.

These parts are not recommended for new designs. They are replaced by new lead free and halogen free versions which are identical in form, fit and function. See www.coilcraft.com/lps3015.cfm.

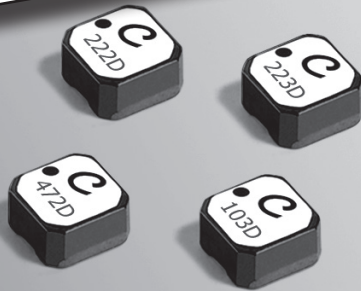

- Very low DCR; excellent current handling
- AEC-Q200 Grade 3 (-40°C to +85°C)
- Miniature 3.0 x 3.0 mm footprint; less than 1.5 mm tall

Core material Ferrite

Core and winding loss See www.coilcraft.com/coreloss

Terminations RoHS compliant silver-palladium-platinum-glass frit. Other terminations available at additional cost.

Weight 40 – 45 mg

Ambient temperature -40°C to +105°C with (40°C rise) Irms current.

Maximum part temperature +145°C (ambient + temp rise). **Derating.**

Storage temperature Component: -40°C to +145°C.

Tape and reel packaging: -40°C to +80°C

Resistance to soldering heat Max three 40 second reflows at

+260°C, parts cooled to room temperature between cycles

Moisture Sensitivity Level (MSL) 1 (unlimited floor life at <30°C / 85% relative humidity)

Failures in Time (FIT) / Mean Time Between Failures (MTBF)

38 per billion hours / 26,315,789 hours, calculated per Telcordia SR-332

Packaging 1000/7" reel; 3500/13" reel; Plastic tape: 12 mm wide, 0.26 mm thick, 8 mm pocket spacing, 1.65 mm pocket depth

Recommended pick and place nozzle OD: 3 mm; ID: ≤ 1.5 mm

PCB washing Tested to MIL-STD-202 Method 215 plus an additional aqueous wash. See [Doc787_PCB_Washing.pdf](#)

Part number ¹	Inductance ² ±20% (µH)	DCR max ³ (Ohms)	SRF typ ⁴ (MHz)	Isat (A) ⁵			Irms (A) ⁶	
				10% drop	20% drop	30% drop	20°C rise	40°C rise
LPS3015-102ML_	1.0	0.075	190	1.8	2.0	2.1	1.4	2.0
LPS3015-152ML_	1.5	0.100	140	1.8	2.1	2.2	1.3	1.7
LPS3015-182ML_	1.8	0.100	135	1.5	1.7	2.1	1.1	1.4
LPS3015-222ML_	2.2	0.110	110	2.0	2.0	2.1	1.1	1.4
LPS3015-332ML_	3.3	0.130	90	1.4	1.5	1.5	1.0	1.4
LPS3015-472ML_	4.7	0.200	79	1.1	1.2	1.2	0.90	1.2
LPS3015-682ML_	6.8	0.300	58	0.83	0.86	0.89	0.68	0.90
LPS3015-103ML_	10	0.440	48	0.60	0.69	0.73	0.55	0.75
LPS3015-153ML_	15	0.700	35	0.58	0.61	0.62	0.44	0.59
LPS3015-183ML_	18	0.750	33	0.56	0.58	0.59	0.43	0.58
LPS3015-223ML_	22	0.825	30	0.48	0.49	0.50	0.42	0.57
LPS3015-333ML_	33	1.30	23	0.39	0.41	0.42	0.35	0.48
LPS3015-473ML_	47	1.55	17	0.36	0.38	0.39	0.30	0.40
LPS3015-683ML_	68	2.35	14	0.29	0.30	0.31	0.25	0.33
LPS3015-104ML_	100	3.40	11	0.24	0.25	0.26	0.19	0.26
LPS3015-124ML_	120	4.65	9.0	0.21	0.22	0.22	0.17	0.23
LPS3015-154ML_	150	6.25	8.0	0.19	0.20	0.20	0.15	0.20
LPS3015-184ML_	180	8.60	7.5	0.16	0.17	0.17	0.13	0.175
LPS3015-224ML_	220	9.50	6.0	0.15	0.16	0.16	0.11	0.155
LPS3015-334ML_	330	23.0	5.0	0.10	0.11	0.11	0.070	0.095

1. Please specify **termination** and **packaging** codes:

LPS3015-333MLC

Termination: L = RoHS compliant silver-palladium-platinum-glass frit.
Special order: T = RoHS tin-silver-copper (95.5/4/0.5) or S = non-RoHS tin-lead (63/37).

Packaging: C = 7" machine-ready reel. EIA-481 embossed plastic tape (1000 parts per full reel).

B = Less than full reel. In tape, but not machine ready. To have a leader and trailer added (\$25 charge), use code letter C instead.

D = 13" machine-ready reel. EIA-481 embossed plastic tape. Factory order only, not stocked (3500 per full reel).

- Inductance tested at 100 kHz, 0.1 Vrms using an Agilent/HP 4192A. Inductance at 1 MHz is the same for parts with SRF ≥ 10 MHz.
- DCR measured on a micro-ohmmeter.
- SRF measured using Agilent/HP 8753ES or equivalent.
- DC current at 25°C that causes the specified inductance drop from its value without current.
[Click for temperature derating information.](#)
- Current that causes the specified temperature rise from 25°C ambient. This information is for reference only and does not represent absolute maximum ratings. [Click for temperature derating information.](#)
- Electrical specifications at 25°C.

Refer to Doc 362 "Soldering Surface Mount Components" before soldering.

Coilcraft[®]

www.coilcraft.com

US +1-847-639-6400 sales@coilcraft.com

UK +44-1236-730595 sales@coilcraft-europe.com

Taiwan +886-2-2264 3646 sales@coilcraft.com.tw

China +86-21-6218 8074 sales@coilcraft.com.cn

Singapore + 65-6484 8412 sales@coilcraft.com.sg

Document 436NR-1 Revised 11/22/11

© Coilcraft Inc. 2018

This product may not be used in medical or high risk applications without prior Coilcraft approval. Specification subject to change without notice. Please check web site for latest information.

Shielded SMT Power Inductors – LPS3015 Series

Typical L vs Frequency

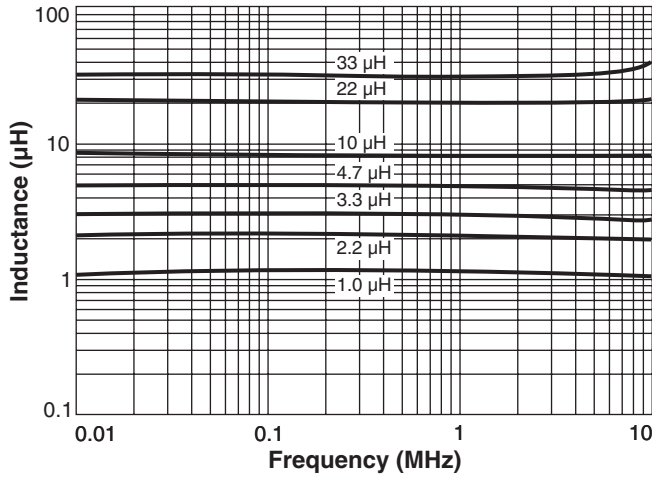

Typical L vs Current

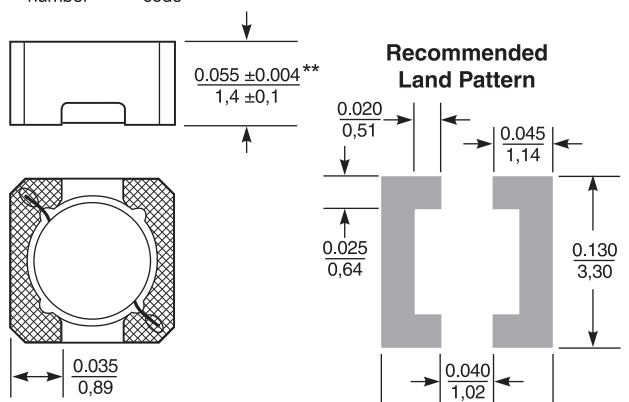
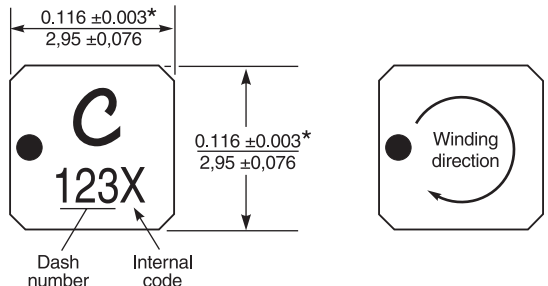
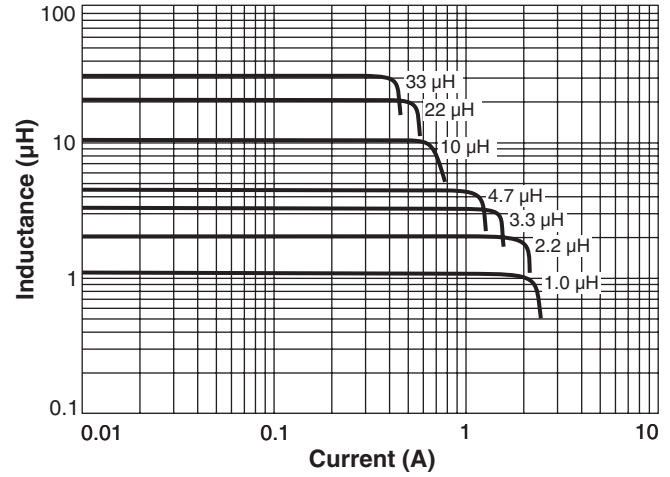

* Dimensions are of the case not including the termination. For maximum overall dimensions including the termination, add 0.005 in / 0,13 mm.

**For optional tin-lead and tin-silver-copper terminations, dimensions are for the mounted part. Dimensions before mounting can be an additional 0.005 inch (0,13 mm).

Dimensions are in **inches**
mm

1000/7" reel; 3500/13" reel; Plastic tape: 12 mm wide, 0.26 mm thick, 8 mm pocket spacing, 1.65 mm pocket depth

Orientation of parts in packaging tape

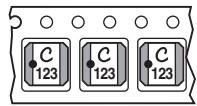

US +1-847-639-6400 sales@coilcraft.com
UK +44-1236-730595 sales@coilcraft-europe.com
Taiwan +886-2-2264 3646 sales@coilcraft.com.tw
China +86-21-6218 8074 sales@coilcraft.com.cn
Singapore + 65-6484 8412 sales@coilcraft.com.sg