

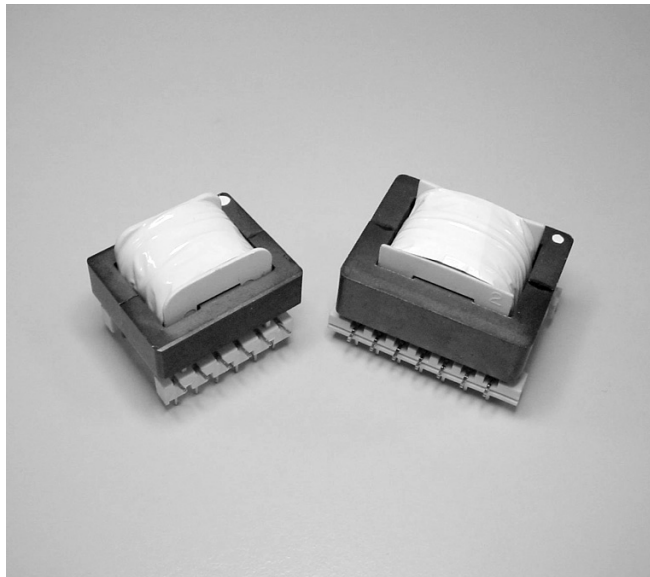

PFC Coils

For ON Semiconductor NCP1653
Power Factor Controller



These coils were developed specifically for use with the ON Semiconductor NCP1653 Power Factor Controller (PFC) for driving continuous conduction mode step-up pre-converters.

The C1061-A operates in 150 Watt applications. The C1062-B operates in 300 Watt applications and is specified by ON Semiconductor in application note AND8185/D.

In addition to the standard parts shown, Coilcraft can design custom magnetics with inductance, DCR and current values to meet your specific requirements. For more information, contact Coilcraft.

To request free evaluation samples of these coils, contact Coilcraft or visit www.coilcraft.com.

Part number	Application	Inductance ¹ ±10% (µH)	Inductance at I _{pk} min (µH)	I _{pk} (A)	DCR max ² (Ohms)	SRF (MHz)	I _{rms} ³ (A)
C1061-AL	150 W	450	405	4.5	0.166	1.4	3.80
C1062-BL	300 W	570	540	6.0	0.226	1.0	3.55

1. Inductance measured at 100 kHz, 0.1 V, 0 Adc using an Agilent/HP 4284A impedance analyzer.
2. DCR measured on Cambridge Technology micro-ohmmeter and Coilcraft CCF858 test fixture.
3. Current that causes a 40°C rise from 25°C ambient.

4. Ambient temperature range: -40°C to +85°C
Storage temperature range: Component: -40°C to +125°C
Tape and reel packaging: -40°C to +80°C
5. Electrical specifications at 25°C.

Typical Inductance vs Frequency

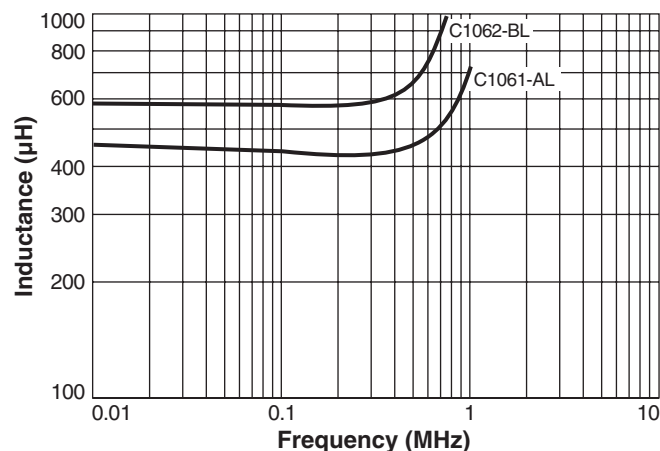

Typical Inductance vs Current

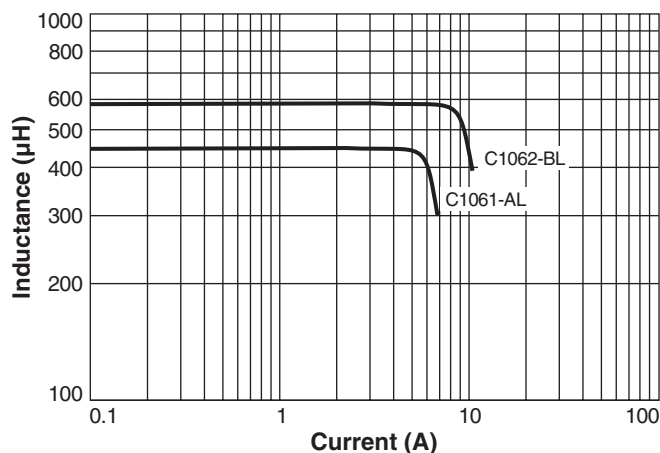

www.coilcraft.com

US +1-847-639-6400 sales@coilcraft.com
UK +44-1236-730595 sales@coilcraft-europe.com
Taiwan +886-2-2264 3646 sales@coilcraft.com.tw
China +86-21-6218 8074 sales@coilcraft.com.cn
Singapore + 65-6484 8412 sales@coilcraft.com.sg

Document 444-1 Revised 12/06/12

© Coilcraft Inc. 2013

This product may not be used in medical or high risk applications without prior Coilcraft approval. Specification subject to change without notice. Please check web site for latest information.



PFC Coils for ON Semiconductor NCP1653

Typical Temperature Rise vs Current

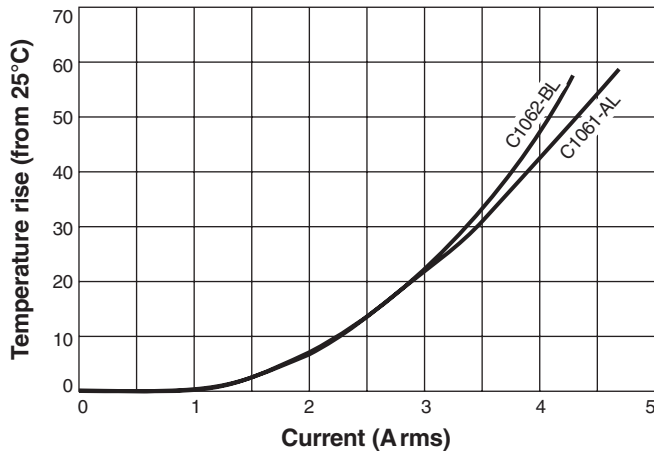

C1061-AL

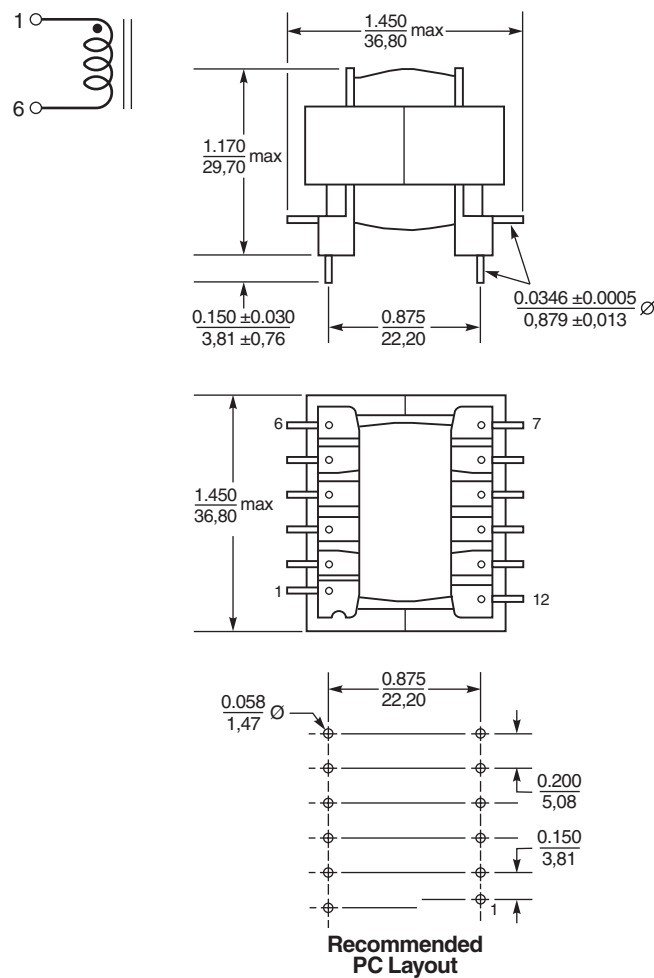

Weight: 64.5 g
Packaging: 75 per tray

C1062-BL

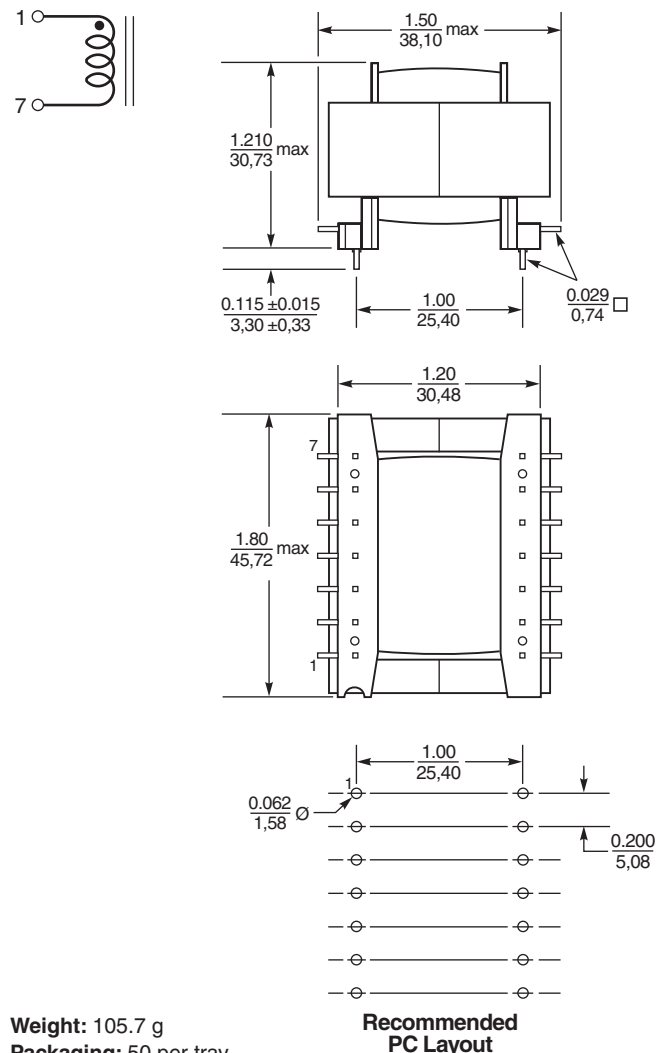

Weight: 105.7 g
Packaging: 50 per tray



US +1-847-639-6400 sales@coilcraft.com
UK +44-1236-730595 sales@coilcraft-europe.com
Taiwan +886-2-2264 3646 sales@coilcraft.com.tw
China +86-21-6218 8074 sales@coilcraft.com.cn
Singapore + 65-6484 8412 sales@coilcraft.com.sg

Document 444-2 Revised 12/06/12
 © Coilcraft Inc. 2013
 This product may not be used in medical or high risk applications without prior Coilcraft approval. Specification subject to change without notice. Please check web site for latest information.